

THE FOLLOWING ITEMS ARE AVAILABLE SEPARATELY AS SERVICE PARTS

PART#	DESCRIPTION	ITEM#
131509	PEDAL ARM	13
131812	PEDAL	11
131510	PEDAL SPRING	12
131512	PEDAL PIN	31

KITS AND ASSEMBLYS FOR SERVICE

134030 SENSOR KIT (INCLUDES ITEMS 1-2)

Note: When Ordering Replacement Parts, Prefix Vendor Part Number with " WIL "

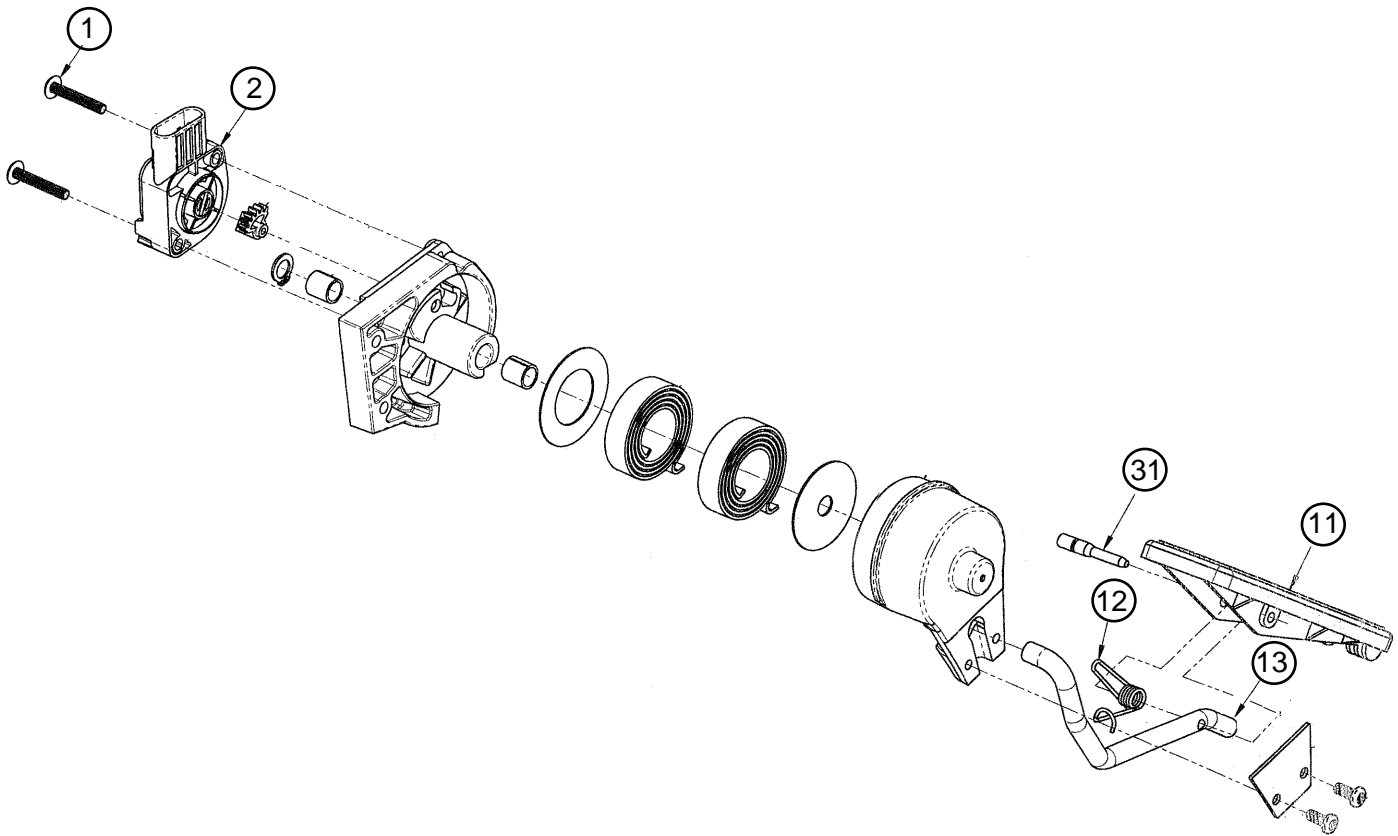

158640- ELECTRONIC THROTTLE PEDAL ASSEMBLY,
DUAL ANALOG SENSOR, MVP-EF, 2010