

RELEASE NUMBER	REV LTR	REVISION DESCRIPTION	BY	DATE	APPD
P40356-07	A	INITIAL RELEASE	JPB	09/29/10	JPD
P40356-19	B	ADDED ITEM 12, AND NOTE 7	JJW	01/11/11	JPD

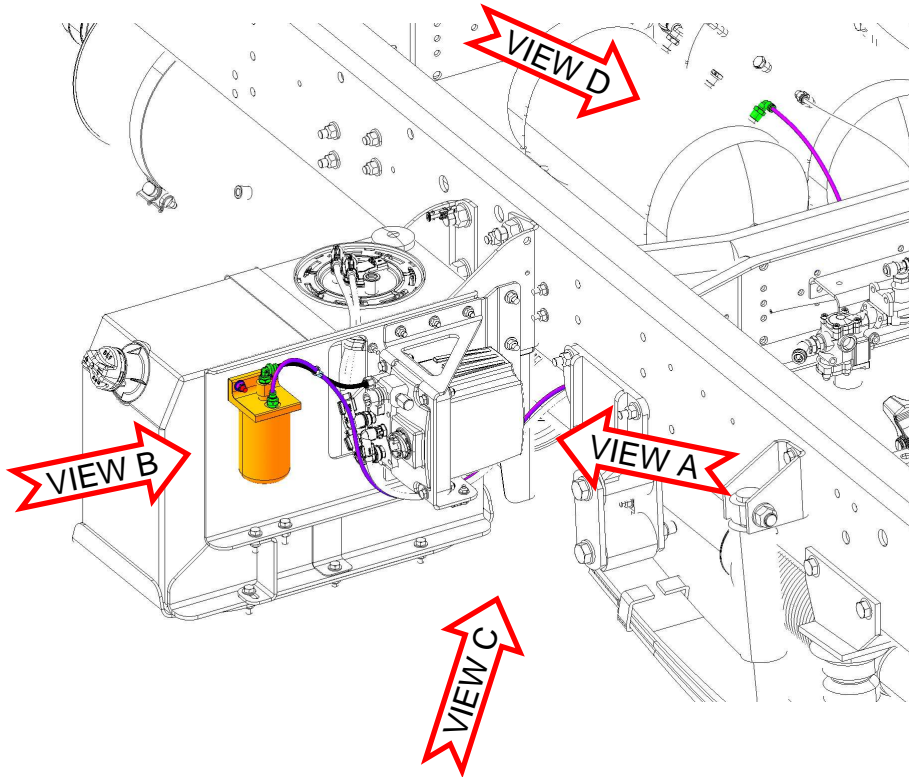

XXX ← BOX HEADER IS MODULE #  
XXX ← SUBSEQUENT BOXES ARE REF #S  
XXX

FTL MODULE #	DESCRIPTION
11A	ENG PERF,AIR FLTR

1. TORQUE FASTENERS PER SPEC 49-00104 (TBB STD 62370002) UNLESS OTHERWISE SPECIFIED.
2. UTILIZE WIRE AND AIR LINE MOUNTING HARDWARE IN MOD 23W.
3. UTILIZE FRONT BRAKE VALVE MOUNTING HARDWARE IN MOD 413.
4. 1/4 NYLON TUBE – AIR FILTER TO ACCESSORY AIR TANK.
5. 1/4 NYLON TUBE – DOSER UNIT TO AIR FILTER.
6. INSTALLATION CREATED USING ARR TBBN169485 IN SMARAGD.
7. REPLACE EXISTING CONNECTOR WITH ITEM 12, TBB #171109

TBBN169485	<b>DAIMLER</b>		Daimler Trucks North America	
	THE INFORMATION CONTAINED HEREIN IS PROPRIETARY DATA, AND IS NOT FOR DISSEMINATION OR DISCLOSURE, IN WHOLE OR IN PART, FOR ANY PURPOSE OTHER THAN THAT FOR WHICH IT IS SUBMITTED, EXCEPT AS AUTHORIZED IN WRITING BY DAIMLER TRUCKS NORTH AMERICA LLC (DTNA)			
	MATERIAL APPROVAL N/A	DATE N/A	UNLESS OTHERWISE NOTED, DIMENSIONS AND TOLERANCES ARE DEFINED ACCORDING TO ASME Y14.5M- 1994, WITH EXCEPTION PER DTNA 09ENG-WI037	
	DRAWN BY J.BRAZITIS	DATE 09/29/10		
CHECKED BY T.BOSTIC	DATE 10/08/10			
RESPONSIBLE ENGINEER J.BRAZITIS	DATE 09/29/10			
APPROVED BY J.DAVIS	DATE 10/08/10	THIRD ANGLE PROJECTION		UNITS OF MEASURE MM
ITEM NUMBER	DESCRIPTION <b>INSTL-ENG PERF,AIR FLTR,EF,E4</b>			
DESCRIPTION	SUPPLEMENTAL DESCRIPTION 11AA1			
ITEM/DRAWING NUMBER	<b>TBBN169485</b>		REVISION LETTER <b>B</b>	PAGE 1 of 4

ITEM	QTY	TBB PART #	FTL PART #	DESCRIPTION
1	1	169486	FG 397729900	AIR FLTR, OIL COALESCING,FLTGRD
2	1	169487	23-13255-000	90 ELB,M12 MALE O-RING X -4
3	1	169488	23-13301-412	CONN-PTC,M12 MALE O-RING X#4
4	1	61361007	SMCKV2L07 36S	ELB-90,1/4NYL X 3/8MPT,GRY
5	2	61370815	23-10744-150	SCREW-CAP,HEX5/16-18X1.5GR8ZWN
6	4	61370347	23-09114-006	WASHER-HRDN,0.34X0.69X.080,ZN
7	2	69004133	23-09336-007	NUT-HEX,CLRLK,5/16-18
8	1	61480481	23-11357-008	CLAMP-HOSE,SGL,CUSH,.500 DIA
9	1	61371426	23-09796-309	CLAMP-CABLE TIE,1-3/4X8
10	AR	170090	48-25855-009	TUBE-NYL 12,1/4" BLACK W/WHITE
11	AR	170090	48-25855-009	TUBE-NYL 12,1/4" BLACK W/WHITE
12	1	171109	PH S7060	CONN-1/4 NYL/M12X1.5-6G

**B**

2 PLACES

11A  
005  
006  
007

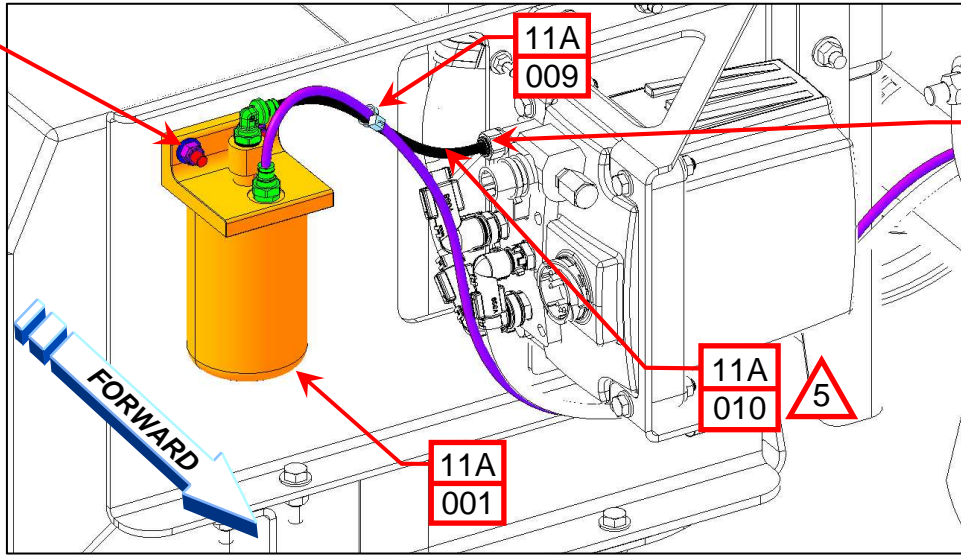

B

11A  
012

7

**VIEW A**

DOSER UNIT SHIELD NOT SHOWN  
FOR CLARITY

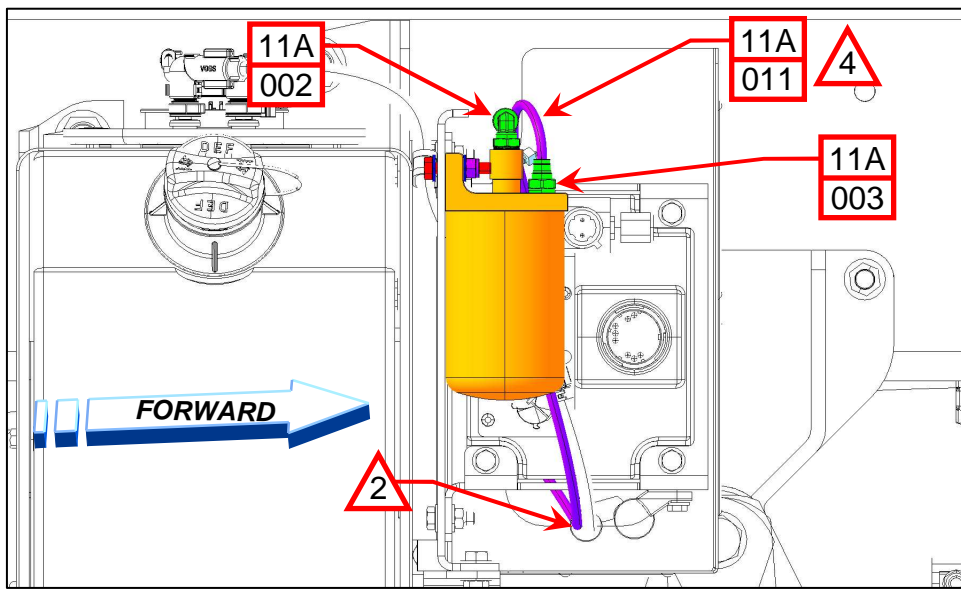

**VIEW B**

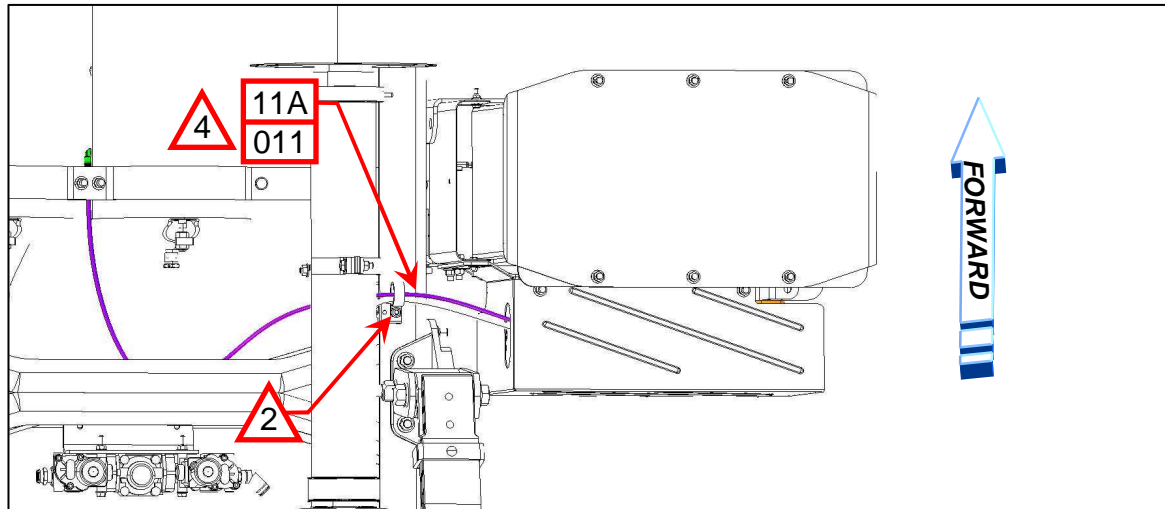

**VIEW C**

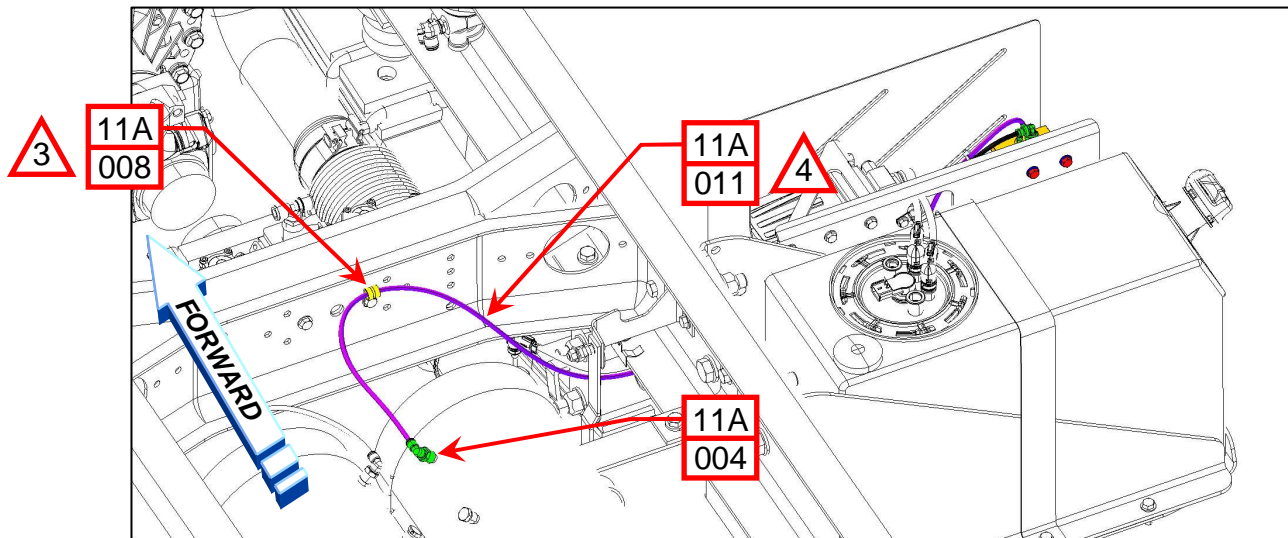

**VIEW D**