

RELEASE NUMBER	REV LTR	REVISION DESCRIPTION	BY	DATE	APPD
P40356-08	A	INITIAL RELEASE	JPB	10/25/10	JPD

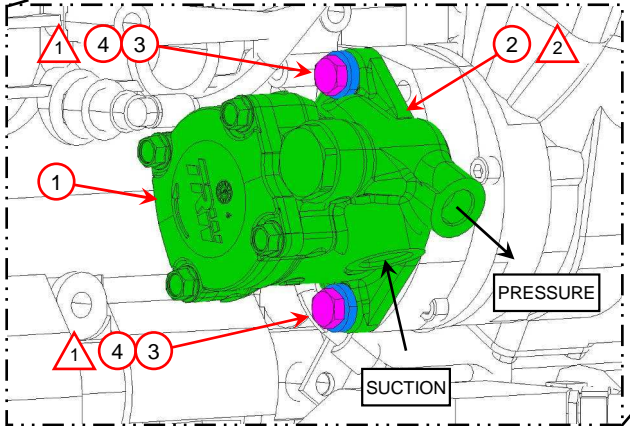
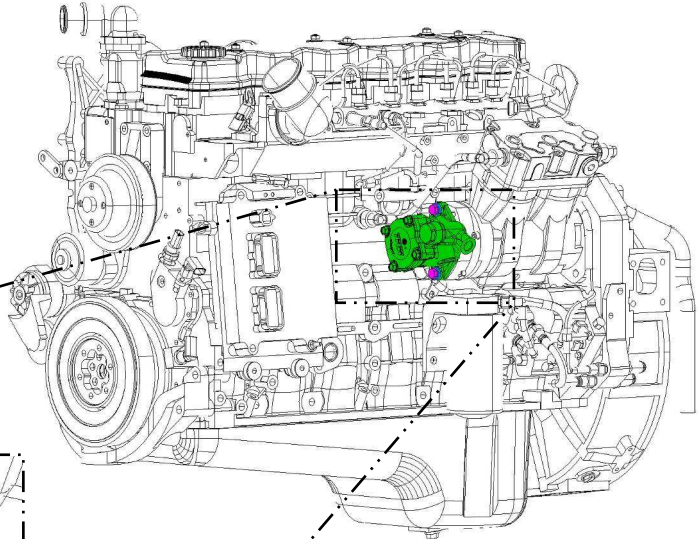

BILL OF MATERIAL				
REF #	FTL PART #	TBB PART #	DESCRIPTION	QTY
1	14-14323-014	170274	PUMP-STRG,TRW,EV,20/16/185,LH	1
2	F4HT 3K506 A A	61280017	GASKET-PWR STNG PUMP MTNG	1
3	000933 010049	61370885	SCREW-CAP,HEX,M10X30 10.9 P/O	2
4	23-09114-002	61370350	WASHER-HRDN,0.41X0.81X.080,ZN	2

- 1 TORQUE FASTENERS TO 50 FT-LBS.
- 2 REMOVE AND DISCARD TEMPORARY FLANGE COVER AND GASKET. INSTALL NEW GASKET, ITEM 2.
- 3. HYDRAULIC STEERING PUMP MUST MEET DTNA CLEANLINESS AND PERFORMANCE REQUIREMENTS PER SPEC 49-00226.
- 4. TBB ECR/CR NUMBER: CR_F6833-8.

DAIMLER Daimler Trucks North America		<small>THE INFORMATION CONTAINED HEREIN IS PROPRIETARY DATA, AND IS NOT FOR DISSEMINATION OR DISCLOSURE, IN WHOLE OR IN PART, FOR ANY PURPOSE OTHER THAN THAT FOR WHICH IT IS SUBMITTED, EXCEPT AS AUTHORIZED IN WRITING BY DAIMLER TRUCKS NORTH AMERICA LLC (DTNA).</small>	
		<small>UNLESS OTHERWISE NOTED, DIMENSIONS AND TOLERANCES ARE DEFINED ACCORDING TO ASME Y14.5M-1994 WITH EXCEPTION PER DTNA 09ENG-WI037</small>	<small>UNITS OF MEASURE MM</small>
TBBN170273 INSTL-STRG PUMP,ISB,EF	MATERIAL APPROVAL	DATE	
	X.XXX DRAWN BY J.BRAZITIS	XX/XX/XX DATE 10/25/10	
	CHECKED BY T.BOSTIC	DATE 10/29/10	
	RESPONSIBLE ENGINEER J.BRAZITIS	DATE 10/25/10	
APPROVED BY J.DAVIS		DATE 10/29/10	
SUPPLEMENTAL DESCRIPTION INSTL-STRG PUMP,ISB,EF 539A1			
ITEM DRAWING NUMBER TBBN170273		REVISION LETTER A	PAGE 1 of 1